

Surveying made easy

Karl Zeiske



- when it has to be **right**

Leica
Geosystems

Introduction

This booklet will tell you about the basic principles of surveying.

The most important instruments for surveying are levels and total stations; they are intended for routine survey tasks. Anyone wishing to know how and where they are used will find the answers here.

- What are the main features of these instruments?
- What needs to be taken into account when measuring with a level or with a total station?
- What are the effects of instrument errors?
- How can such errors be recognized, determined and eliminated?
- How can simple surveying jobs be performed?

The use of levels and total stations is illustrated by a series of practical examples. In addition, applications programs are described; these are incorporated into the modern total stations manufactured by Leica Geosystems and they solve survey tasks even more easily and elegantly. Equipped with the knowledge in this booklet, and with the help of the appropriate user manual, anyone can carry out simple survey tasks confidently and efficiently. This booklet does not describe the range of instruments available today from Leica Geosystems;

neither does it touch on their individual performance features. These aspects are covered by the comprehensive brochures, by the technical consultants in the Leica Geosystems agencies, and by the home pages in the Internet (www.leica-geosystems.com).

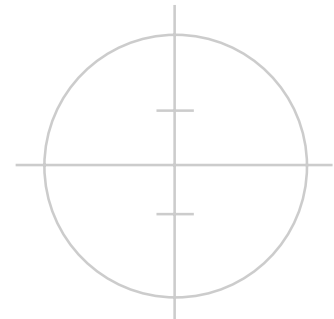

Contents

The level	4	Measuring distances without a reflector	19
The total station	5	Automatic target recognition	19
Coordinates	6	Setting out profile boards	20
Measuring angles	7	Instrument errors	22
Preparing to measure	8	Inspecting the line of sight	22
Setting up the instrument anywhere	8	Inspecting the EDM of the total station	23
Levelling-up the instrument	8	Instrument errors in the total station	24
Setting up the total station over a ground point	9	Simple surveying tasks	26
Measuring with the level	10	Aligning from the mid-point	26
Height difference between two points	10	Measuring slopes	27
Measuring distances optically with the level	11	Measuring right-angles	28
Line levelling	12	Applications programs	29
Staking out point heights	13	Calculating areas	29
Longitudinal and transverse profiles	14	Staking out	30
The digital level	15	Remote heights	31
The rotation laser	15	Tie distances	32
Measuring with the total station	16	Free-station surveys	33
Extrapolating a straight line	16	The applications programs available	34
Polar setting-out of a point	16	Surveying with GPS	35
Plumbing down from a height point	17		
Surveys (polar method)	18		

The level

A level essentially comprises a telescope rotatable about a vertical axis; it is used to create a horizontal line of sight so that height differences can be determined and stakeouts can be performed.

The Leica Geosystems levels are also equipped with a horizontal circle that is very useful for setting out right angles, e.g. during the recording of transverse profiles. In addition, these levels can be used to determine distances optically with an accuracy to 0.1 – 0.3 metres.



The total station

A total station consists of a theodolite with a built-in distance meter (distaner), and so it can measure angles and distances at the same time. Today's electronic total stations all have an opto-electronic distance meter (EDM) and electronic angle scanning. The coded scales of the horizontal and vertical circles are scanned electronically, and then the angles and distances are displayed digitally. The horizontal distance, the height difference and the coordinates are calculated automatically and all measurements and additional information can be recorded.

Leica total stations are supplied with a software package that enables most survey tasks to be carried out easily, quickly and elegantly. The most important of these programs are presented in the section "Applications programs".

Total stations are used wherever the positions and heights of points, or merely their positions, need to be determined.

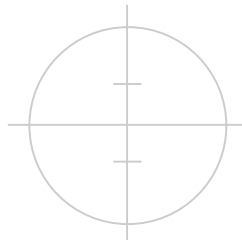

Coordinates

In order to describe the position of a point, two coordinates are required. Polar coordinates need a line and an angle. Cartesian coordinates need two lines within an orthogonal system. The total station measures polar coordinates; these are recalculated as Cartesian coordinates within the given orthogonal system, either within the instrument itself or subsequently in the office.

Direction of reference

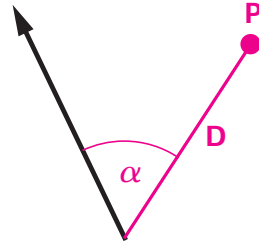

Polar coordinates

Recalculation

given: D, α
required: x, y

$$y = D \sin \alpha$$
$$x = D \cos \alpha$$

Abscissa (x)

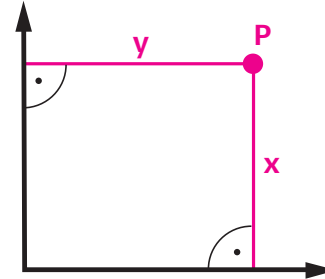

Ordinate (y)

Cartesian coordinates

given: x, y
required: D, α

$$D = \sqrt{y^2 + x^2}$$
$$\sin \alpha = y/D \quad \text{or}$$
$$\cos \alpha = x/D$$

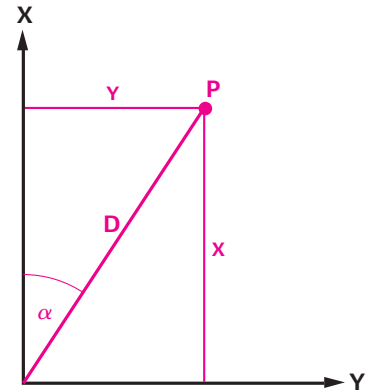

Measuring angles

An angle represents the difference between two directions.

The horizontal angle α between the two directions leading to the points P_1 and P_2 is independent of the height difference between those points, provided that the telescope always moves in a strictly vertical plane when tilted, whatever its horizontal orientation. This stipulation is met only under ideal conditions.

The vertical angle (also termed the zenith angle) is the difference between a prescribed direction (namely the direction of the zenith) and the direction to the point under consideration.

The vertical angle is therefore correct only if the zero reading of the vertical circle lies exactly in the zenith direction, and also this stipulation is met only under ideal conditions.

Deviations from the ideal case are caused by axial errors in the instrument and by inadequate levelling-up (refer to section: "Instrument errors").

Z_1 = zenith angle to P_1
 Z_2 = zenith angle to P_2

α = Horizontal angle between the two directions to the points P_1 and P_2 , i.e. the angle between two vertical planes formed by dropping perpendiculars from P_1 and P_2 respectively

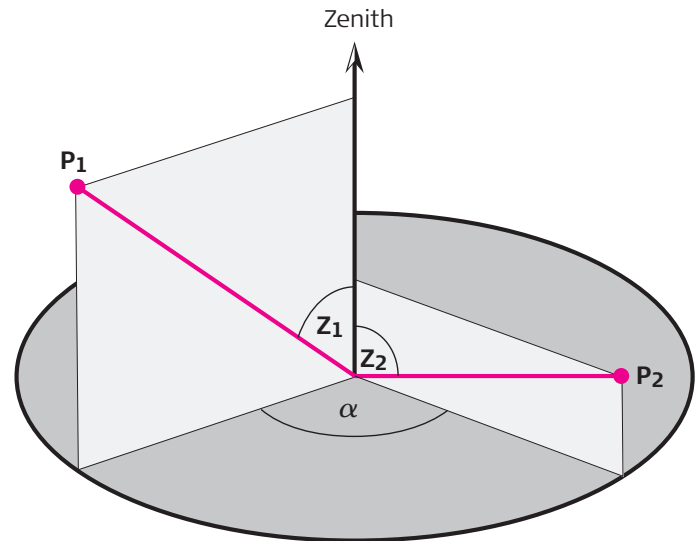

Setting up the instrument anywhere

1. Extend the legs of the tripod as far as is required and tighten the screws firmly.
2. Set up the tripod so that the tripod plate is as horizontal as possible and the legs of the tripod are firm in the ground.
3. Now, and only now, place the instrument on the tripod and secure it with the central fixing screw.

Levelling-up the instrument

After setting up the instrument, level it up approximately with the bull's-eye bubble.

Turn two of the footscrews together in opposite directions. The index finger of your right hand indicates the direction in which the bubble should move (illustration, top right). Now use the third footscrew to centre the bubble (illustration, bottom right).

To check, rotate the instrument 180°. Afterwards, the bubble should remain within the setting circle. If it does not, then readjustment is required (refer to the user manual).

For a level, the compensator automatically takes care of the final levelling-up. The compensator consists

basically of a thread-suspended mirror that directs the horizontal light beam to the centre of the crosshair even if there is residual tilt in the telescope (illustration, bottom).

If now you lightly tap a leg of the tripod, then (provided the bull's-eye bubble is centred) you will see how the line of sight swings about the staff reading and always steadies at the same point. This is the way to test whether or not the compensator can swing freely.

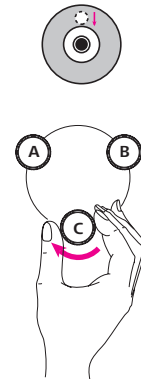
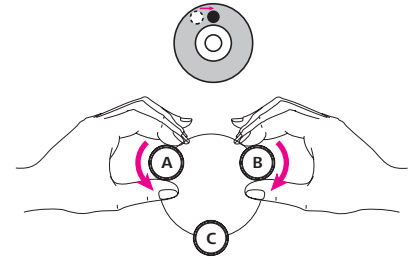
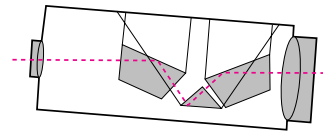

Setting up the total station over a ground point

1. Place the tripod approximately over the ground point.
2. Inspect the tripod from various sides and correct its position so that the tripod plate is roughly horizontal and above the ground point (illustration, top left).
3. Push the tripod legs firmly into the ground and use the central fixing screw to secure the instrument on the tripod.
4. Switch on the laser plummet (or, for older instruments, look through the optical plummet) and turn the footscrews so that the laser dot or the optical plummet is centred on the ground point (illustration, top right).
5. Centre the bull's-eye bubble by adjusting the lengths of the tripod legs (illustration below).
6. After accurately levelling up the instrument, release the central fixing screw so that you can displace it on the tripod plate until the laser dot is centred precisely over the ground point.
7. Tighten the central fixing screw again.

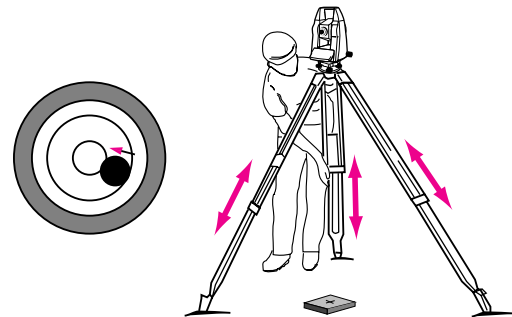
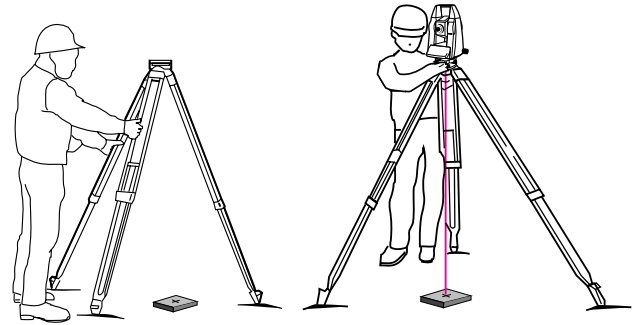

Height difference between two points

The basic principle of levelling involves determining the height difference between two points.

To eliminate systematic errors related to atmospheric conditions or to residual line-of-sight error, the instrument should be about equidistant from the two points.

The height difference is calculated from the difference between the two staff readings for the points A and B respectively.

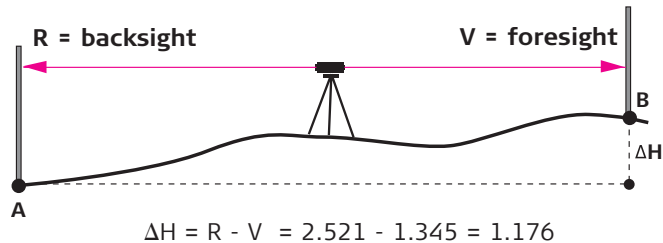

Reading: 2.521

Reading: 1.345

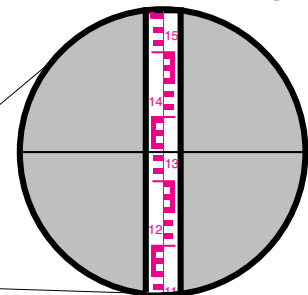
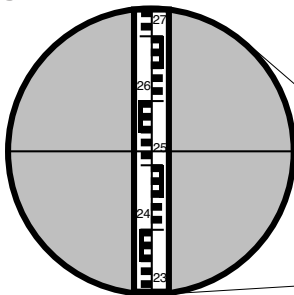

Measuring distances optically with the level

The reticle carries two stadia lines arranged symmetrically to the crosshair. Their spacing is such that the distance can be derived by multiplying the corresponding staff section by 100. (This diagram is a schematic representation).

Accuracy of the distance measurement:
10 – 30 cm

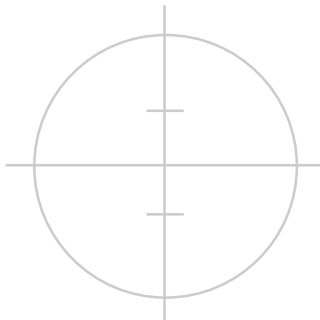

Example:

Reading on upper

stadia line $B = 1.829$

Reading on lower

stadia line $A = 1.603$

Staff section

$$l = B - A = 0.226$$

$$\text{Distance} = 100 l = 22.6 \text{ m}$$

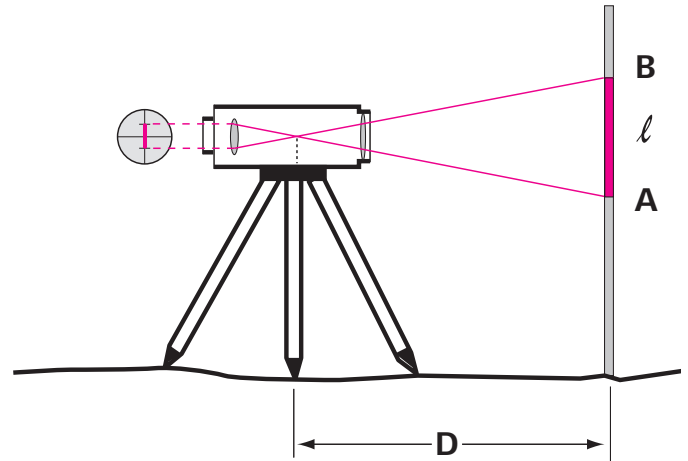

Line levelling

If the points A and B are widely separated, the height difference between them is determined by line levelling with target distances generally between 30 and 50 metres.

Pace out the distances between the instrument and the two staffs; they need to be about the same.

1. Set up the instrument at S_1 .
2. Set up the staff precisely vertically at point B; read off and record the height (backsight R).
3. Set up the staff at the turning point 1 (ground plate or prominent ground point); read off and record the height (foresight V).

4. Set up the instrument at S_2 (the staff remains at the turning point 1).
5. Carefully rotate the staff at the turning point 1 so that it faces the instrument.
6. Read off the backsight and continue.

The height difference between A and B is equal to the sum of the backsight and the foresight.

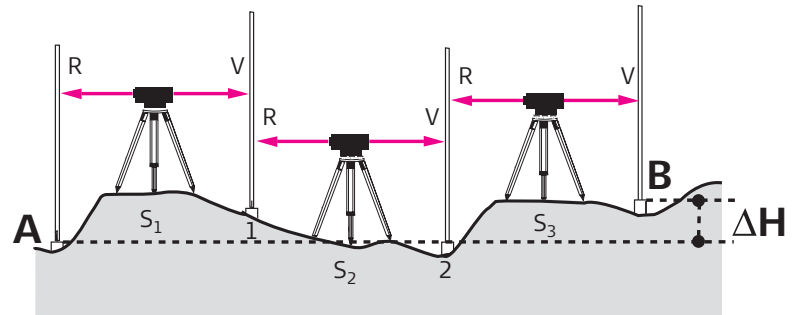

Station	Point no.	Backsight R	Foresight V	Height	Remarks
	A			420.300	
S_1	A	+2.806			
	1		-1.328	421.778	= height A+R-V
S_2	1	+0.919			
	2		-3.376	419.321	
S_3	2	+3.415			
	B		-1.623	421.113	
Sum		+7.140 -6.327	-6.327	+0.813	= height B - height A
ΔH		+0.813			= height difference AB

Staking out point heights

In an excavation, a point B is to be set out at a height $\Delta H = 1.00$ metre below street level (Point A).

1. Set up the level so that the sighting distances to A and B are about the same.
2. Set up the staff at A and read off the backsight $R = 1.305$.
3. Set up the staff at B and read off the foresight $V = 2.520$.

The difference h from the required height at B is calculated as:

$$h = V - R - \Delta H = 2.520 - 1.305 - 1.00 = +0.215 \text{ m}$$

4. Drive in a post at B and mark the required height (0.215 m above ground level).

In another frequently-used method, the required staff reading is calculated in advance:

$$V = R - \Delta H = 1.305 - (-1.000) = 2.305$$

The levelling staff is then moved upwards or downwards until the required value can be read off with the level.

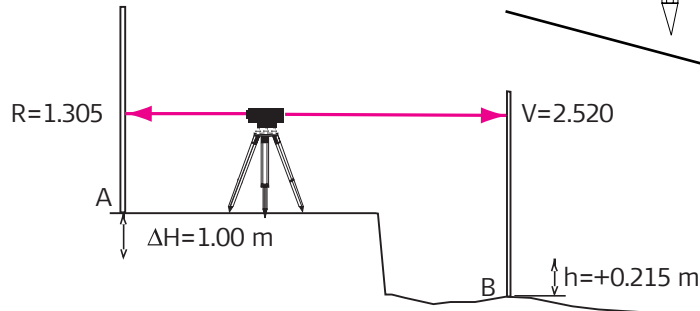
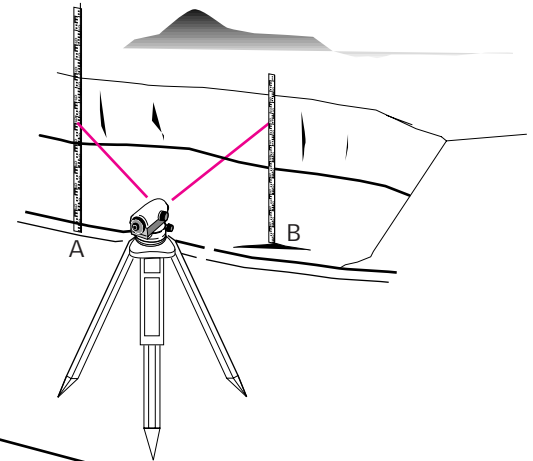

Longitudinal and transverse profiles

Longitudinal and transverse profiles form the basis for the detailed planning and stakeout of communications routes (e.g. roads) and also for the calculation of fill and for the best possible accommodation of the routes to the topography. First of all the longitudinal axis (roadline) is staked out and stationed; this means that points are established and marked at regular intervals. A longitudinal profile is then created along the roadline, the heights of the station points being determined by line levelling. At the station points and at prominent topographic features, transverse profiles (at right-angles to the roadline) are then recorded. The ground heights for the points in the transverse profile are determined with the aid of the known instrument

height. First, position the staff at a known station point; the instrument height comprises the sum of the staff reading and the station point height. Now subtract the staff readings (at the points on the transverse profile) from the instrument height; this gives the heights of the points involved. The distances from the station point to the various points in the transverse profiles are determined either with the surveyor's tape or optically using the level. When representing a longitudinal profile graphically, the heights of the station points are expressed at a much bigger scale (e.g. 10x greater) than that of the stationing of the longitudinal direction, which is related to a round reference height (illustration above).

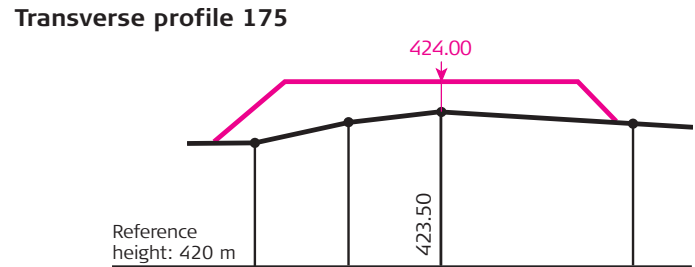
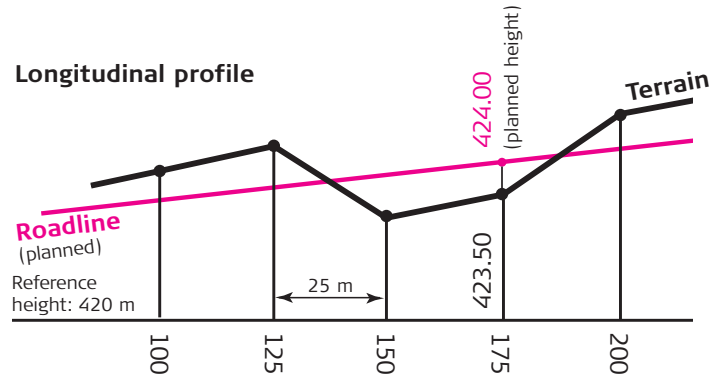

The digital level

The digital levels from Leica Geosystems are the first ones in the world to be equipped with digital electronic image processing for the determination of heights and distances; the bar code on a staff is read by electronic means, completely automatically (see illustration).

The staff reading and the distance are displayed digitally and can be recorded;

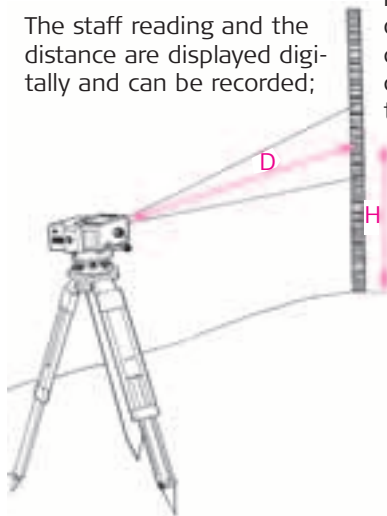

the heights of the staff stations are calculated continuously and so there can be no errors related to reading, recording and calculating. Leica Geosystems can offer software packages for post-processing the recorded data.

A digital level is recommended for use where a lot of levelling needs to be carried out; under these circumstances the saving in time can amount to 50%.

The rotation laser

If, on a large construction site for example, a large number of points at different heights need to be staked out or monitored, it often makes sense to use a rotation laser. In this type of instrument, a rotating laser beam sweeps out a horizontal plane, which serves as the reference plane for staking out or monitoring heights such as four-foot marks.

A detector is slid down a levelling staff until it encounters the laser beam; the height can then be read directly from the staff. There is no need for an observer at the instrument station.

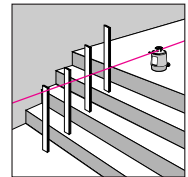
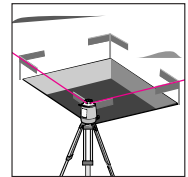
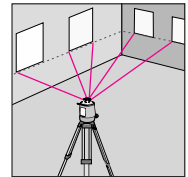
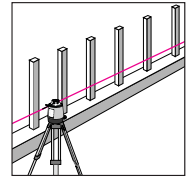

Extrapolating a straight line

1. Position the instrument at point B.
2. Target point A, transit the telescope (i.e. reverse it) and mark point C_1 .
3. Turn the instrument 200 gon (180°) and target point A again.
4. Transit the telescope again and mark the point C_2 . Point C, the mid-point between C_1 and C_2 , corresponds exactly to the extrapolation of the line AB.

A line-of-sight error is responsible for the discrepancy between C_1 and C_2 .

Where the line of sight is inclined, the influence of the errors is a combination of target error, tilting-axis error and vertical-axis error.

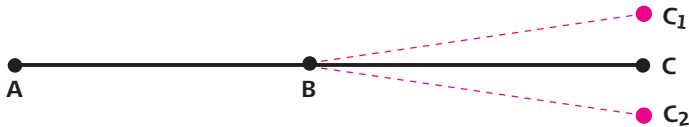

Polar setting-out of a point

The setting-out elements (angle and distance) here relate to a known point A and to a known starting direction from A to B.

1. Set up the instrument at point A and target the point B.
2. Set the horizontal circle to zero (refer to the user manual).

3. Rotate the instrument until a appears in the display.
4. Guide the reflector carrier (person) into and along the line of sight of the telescope, continually measuring the horizontal distance until point P is reached.

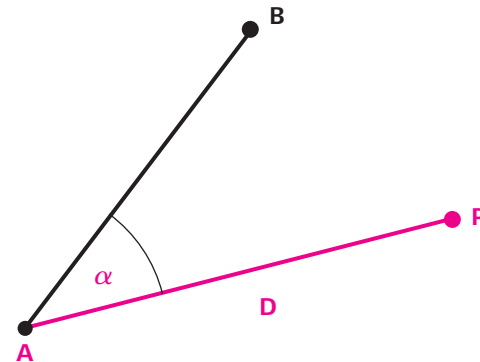

Plumbing down from a height point

Plumbing down from a height point, plumbing up from a ground point, and inspecting a vertical line on a structure, can be carried out exactly in just one telescope face, but only if the telescope describes a precisely-vertical plane when it is tilted. To ascertain that this is so, proceed as follows:

1. Target a high point A, then tilt the telescope downwards and mark the ground point B.
2. Transit the telescope, and repeat the procedure in the second face. Mark the point C.

The mid-point between the points B and C is the exact plumbing point.

The reason why these two points do not coincide can be a tilting-axis error and/or an inclined vertical axis.

For work of this type, make sure that the total station has been levelled up precisely, so that the influence of vertical-axis tilt on steep sights is minimized.

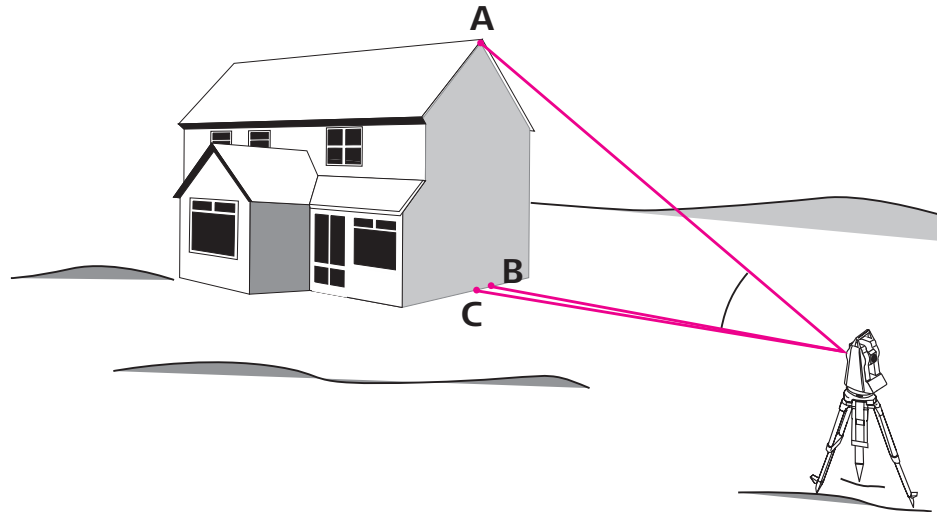

Surveys (polar method)

To create e.g. a location plan, the position and height of a point on the object are determined by measuring angles and distances. To do this, the instrument is set up on any prominent point in a local coordinate system. A second prominent point is selected for the purposes of orientation; after this has been targeted the horizontal circle is set to zero (refer to the user manual).

If a coordinate system already exists, set up the instrument on a known point within it and line up the horizontal circle with a second known point (refer to the user manual).

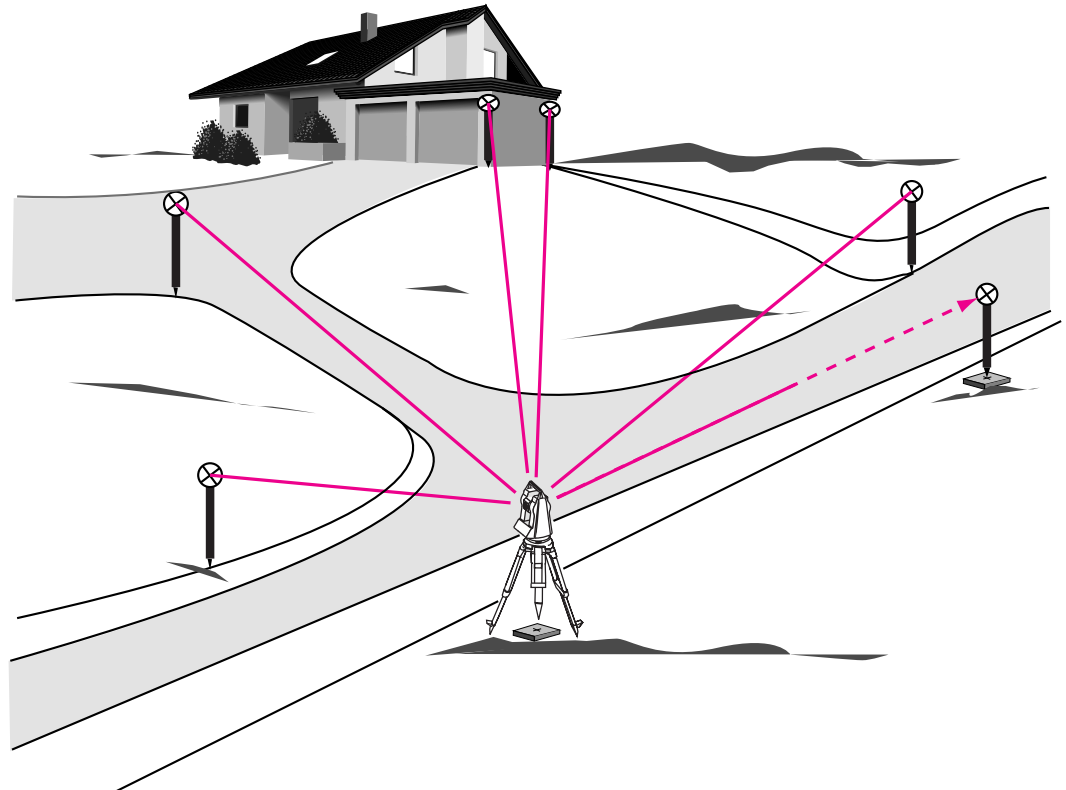

Measuring distances without a reflector

Each of the TCR total stations from Leica Geosystems includes not only a conventional infrared distancer that measures to prisms, but also an integrated laser distancer that requires no reflector. You can switch between these two distancers.

This arrangement brings many advantages where points are accessible only with difficulty or not at all, for example during the recording of frontages, in positioning pipes and for measurements across gorges or fences.

The visible red laser dot is also suitable for marking targets in connection with the recording of tunnel profiles or with indoor work.

The "DISTO" hand-held laser meter from Leica Geosystems is another simple instrument that uses a visible laser beam and needs no reflector; it is particularly suitable for indoor measurements to ascertain spacings, areas and volumes.



Automatic target recognition

The TCA total stations from Leica Geosystems are equipped with an automatic target-recognition system ("ATR"). This makes targeting faster and easier. It is enough to point the telescope approximately at the reflector; a touch on a button then automatically triggers the fine pointing and the angle- and distance measurements, and records all of the values. This technology also makes it possible to carry out fully-automatic measurements with the help of a computer.

The ATR can also be switched to a mode in which moving targets can be followed and measured; after

establishing the initial contact with the target the instrument locks on to it and tracks it. The practical applications of this option include the precise guidance of construction machinery.

Advantages of ATR: High speed of measurement, combined with a constant measuring accuracy that is independent of the observer.

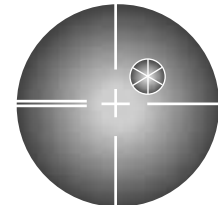

Setting out profile boards

During building alignment, it is useful to extrapolate the sides of the building to beyond the limits of the excavation and there to erect profile boards on which the extensions are marked exactly by hammering in nails. These can be connected to strings or wires at any time during the construction sequence, indicating the required positions of the walls.

In the following example, profile boards are to be erected parallel to the proposed walls of a large building and at distances of a and b respectively from the boundaries (illustration, left).

1. Establish a baseline AB parallel to the left-hand boundary and at a freely-selectable distance c .
2. Mark the point A at the defined distance d from the upper boundary; it will be the first location for the total station.
3. Using a boning rod, mark the point B at the end of the baseline.
4. Set up the total station on point A, target point B, and set out the points A_1 , A_2 and A_3 in this alignment in accordance with the planned length of the side of the building.
5. With point B sighted, set the horizontal circle to zero, turn the total station by 100 gon (90°) and set out the second line AC with the points A_4 , A_5 and A_6 .
6. The points on the profile boards are then set out in a similar manner, starting from the points A_1 to A_6 respectively.

If the foundations have not yet been excavated, you can set out the sides H_1H_2 and H_1H_3 of the building directly and use them as the starting line for marking the points on the profile boards.

For smaller buildings it is easier to set out the profile boards using an optical square (right-angle prism) and a measuring tape.

A building-alignment software program incorporated into many Leica total stations enables profile boards to be set out directly, starting with any instrument station.

Measuring with the total station

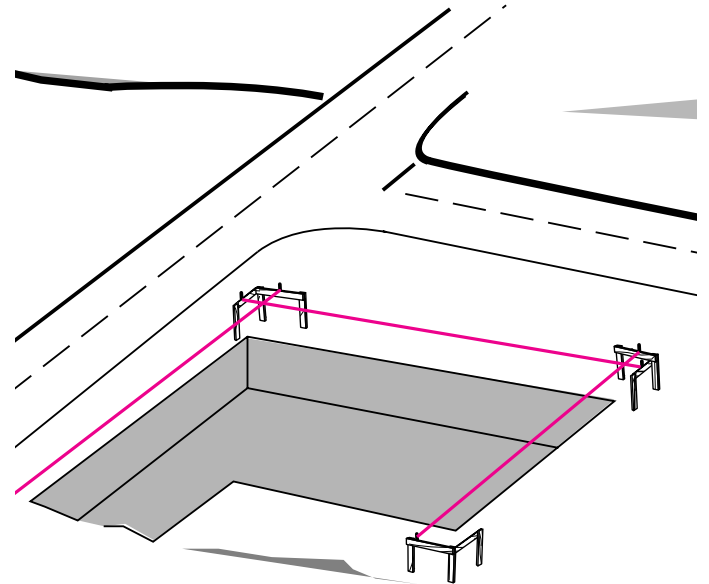
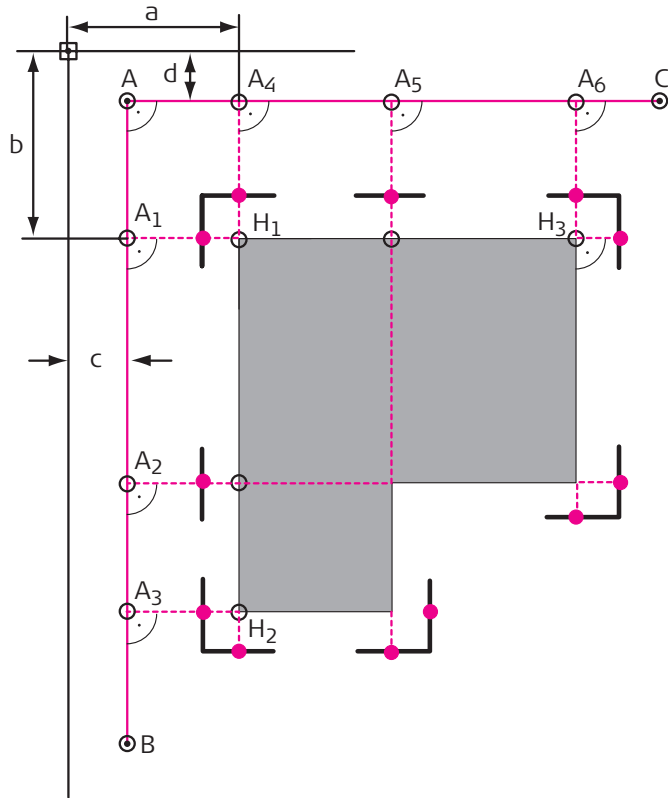

Inspecting the line of sight (two-peg test)

In new levels, the compensator has been adjusted at room temperature, so that the line of sight is horizontal even if the instrument is tilted slightly. This situation changes if the temperature fluctuates by more than ten or fifteen degrees, after a long journey, or if the instrument is subjected to strong vibration. It is then advisable to inspect the line of sight, particularly if more than one target distance is being used.

1. In flat terrain, set up two staffs not more than 30 metres apart.
2. Set up the instrument so that it is equidistant from the two staffs (it is enough to pace out the distance)

3. Read off from both staffs and calculate the height difference (illustration above).

$$\begin{aligned} \text{Staff reading } A &= 1.549 \\ \text{Staff reading } B &= 1.404 \\ \Delta H = A - B &= 0.145 \end{aligned}$$

4. Set up the instrument about one metre in front of staff A and take the staff reading (illustration below).

$$\text{Staff reading } A = 1.496$$

5. Calculate the required reading B:

$$\begin{aligned} \text{Staff reading } A &= 1.496 \\ - \Delta H &= 0.145 \\ \text{Required reading } B &= 1.351 \end{aligned}$$

6. Take the staff reading B. If it differs from the required reading by more than 3 mm, adjust the line of sight (refer to instruction manual).

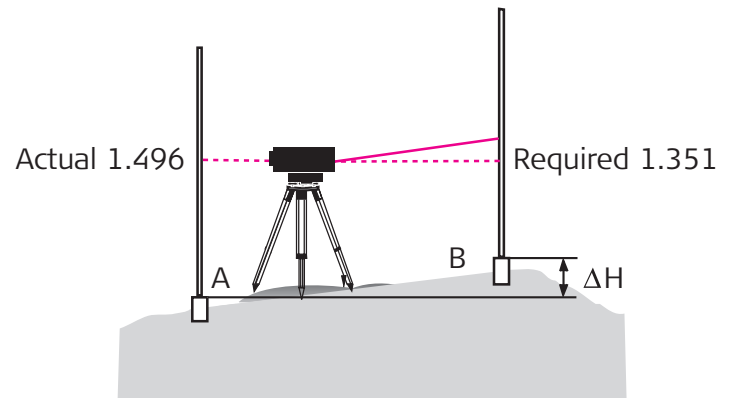
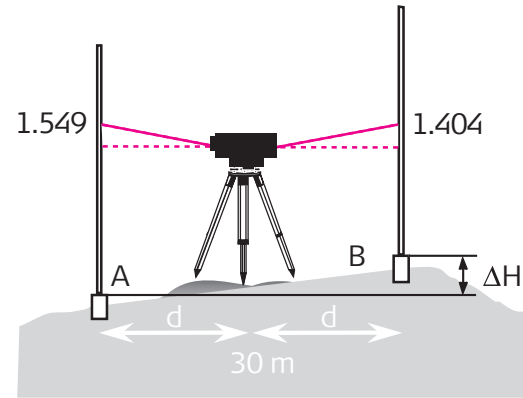

Inspecting the EDM of the total station

Permanently mark four runs within the range typical for the user (e.g. between 20 m and 200 m).

Using a new distancer, or one that has been calibrated on a standard baseline, measure these distances three times.

The mean values, corrected for atmospheric influences (refer to the user manual) can be regarded as being the required values.

Using these four runs, measure with each distancer at least four times per year. Provided that there are no systematic errors in excess of the expected measuring uncertainty, the distancer is in order.

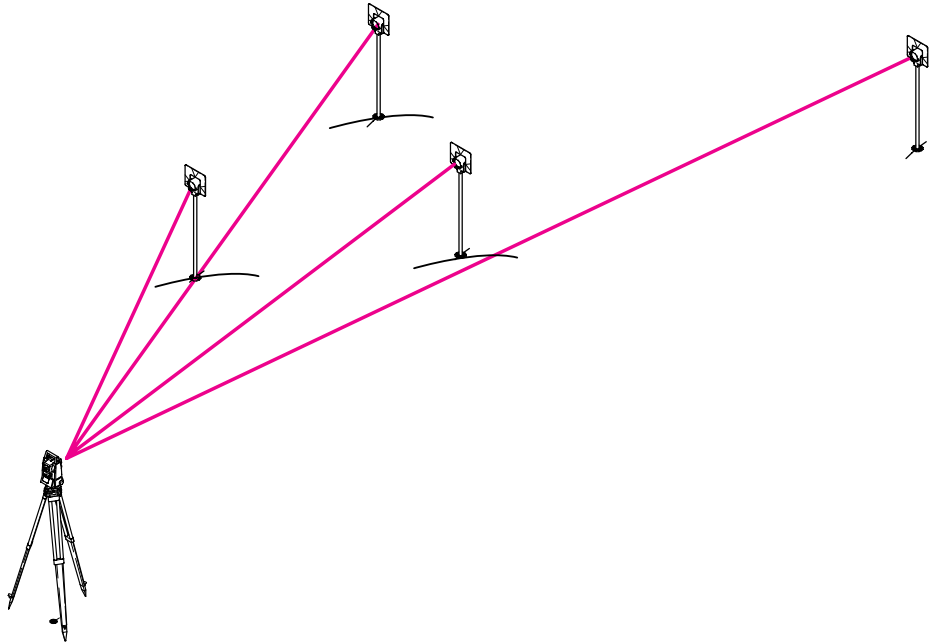

Instrument errors in the total station

Ideally, the total station should meet the following requirements:

- a) Line of sight ZZ perpendicular to tilting axis KK
- b) Tilting axis KK perpendicular to vertical axis VV
- c) Vertical axis VV strictly vertical
- d) Vertical-circle reading precisely zero at the zenith

If these conditions are not met, the following terms are used to describe the particular errors:

- a) Line-of-sight error, or collimation error c (deviation from the right angle between the line of sight and the tilting axis)
- b) Tilting-axis error a (deviation from the right angle between the tilting axis and the vertical axis)
- c) Vertical-axis tilt (angle

between plumb line and vertical axis).

The effects of these three errors on the measurement of horizontal angles increase with the height difference between the target points.

Taking measurements in both telescope faces eliminates line-of-sight errors and tilting-axis errors. The line-of-sight error (and, for highly-precise total stations, also the tilting-axis error, which is generally very small) can also be determined and stored.

These errors are then taken into consideration automatically whenever an angle is measured, and then it is possible to take measurements practically free of error even using just one telescope face. The determination of these errors, and their storage, are described in detail in the appropriate user

manual. Vertical-axis tilt does not rate as being an instrument error; it arises because the instrument has not been adequately levelled up, and measuring in both telescope faces cannot eliminate it. Its influence on the measurement of the horizontal and vertical angles is automatically corrected by means of a two-axis compensator.

- d) Height-index error i (the angle between the zenith direction and the zero reading of the vertical circle, i.e. the vertical-circle reading when using a horizontal line of sight), is not 100 gon (90°), but $100 \text{ gon} + i$.

By measuring in both faces and then averaging, the index error is eliminated; it can also be determined and stored.

Note:

The instrument errors change with temperature, as a result of vibration, and after long periods of transport. If you want to measure in just one face, then immediately before the measurements you must determine the instrument errors and store them.

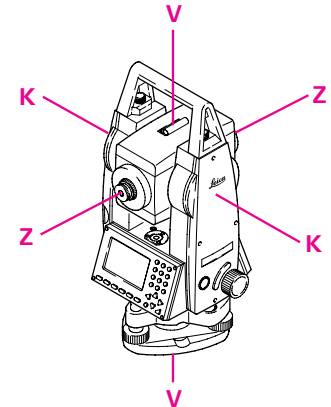

Instrument errors

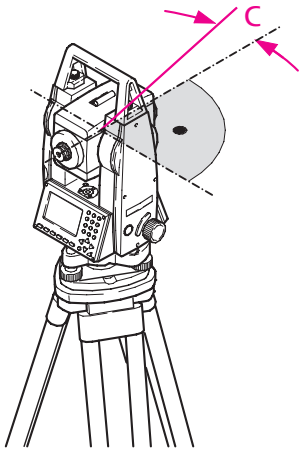

Line-of-sight error (c)
(Hz collimation)

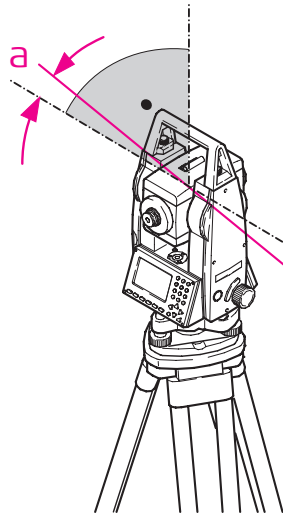

Tilting-axis error (a)

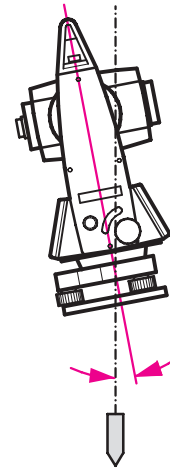

Vertical-axis tilt

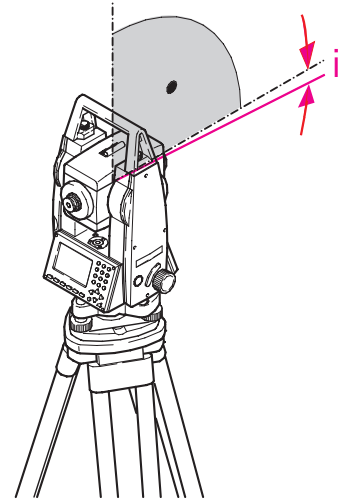

Height-index error (i)
(V index)

Aligning from the mid-point

If intermediate points are to be aligned within a line of measurement and each of the two end points cannot be seen from the other, proceed as follows:

1. Select two points 1 and 2 (both approximately in the alignment) from which both end points A and E are visible. Use sight poles to mark the points.
2. From point 1, align point 2 in the straight line 1 - A
3. From point 2, align point 3 in the straight line 2 - E

4. From point 3, align point 4 in the straight line 3 - A and continue in the same manner until no further lateral deviations are visible at the two intermediate points.

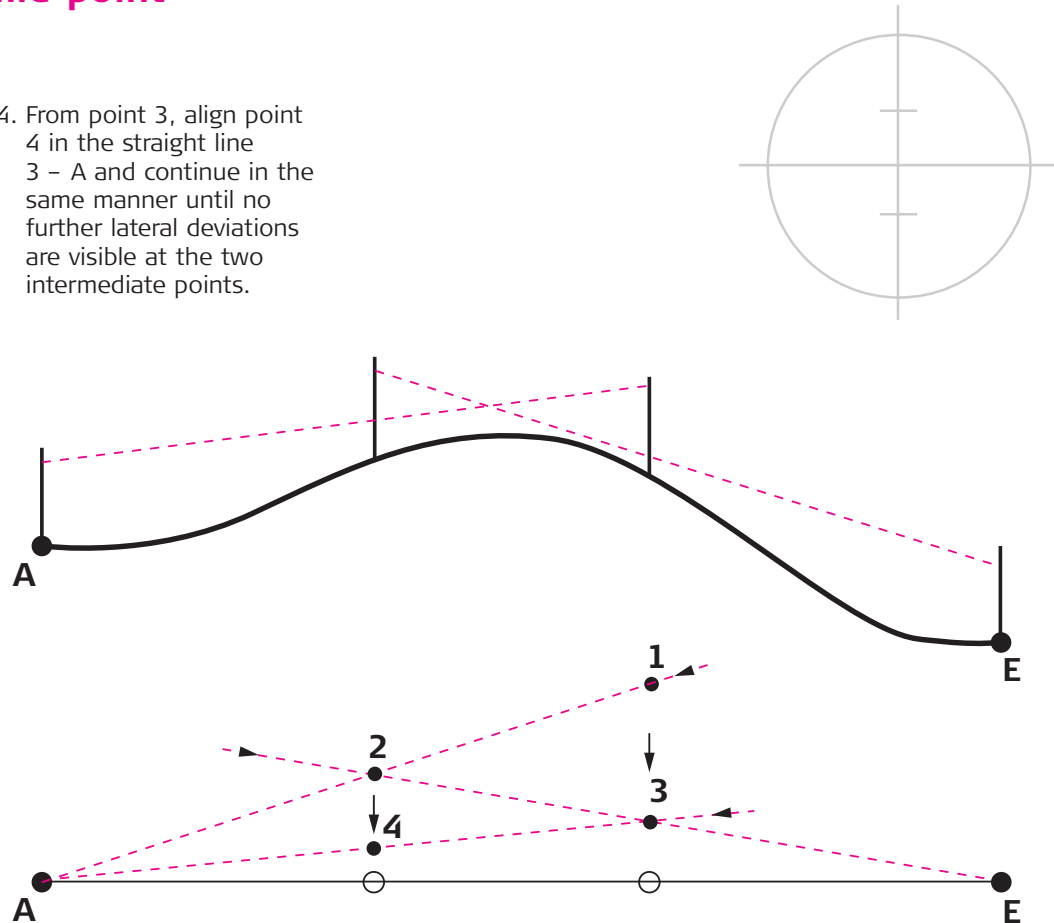

Measuring slopes

If slopes are to be determined in % or to be staked out, e.g. for gutters, pipelines or foundations, two different methods are available.

1. With a level

Measure the height difference and the distance (either optically with the stadia hairs or with the tape). The slope is calculated as follows:
 $100 \Delta H / D = \text{slope in \%}$

2. With a theodolite or total station

Place the instrument on a point along the straight line the slope of which is to be determined, and position a staff at a second point along that line.

Using the telescope, determine the instrument height i at the staff. The vertical-circle reading giving the zenith angle in gon or degrees can be reset to % (refer to user manual) so that the slope can be read off directly in %. The distance is irrelevant.

A reflector pole fitted with a prism can be used instead of the staff. Extend the reflector pole to the instrument height i and use the telescope to target the centre of the prism.

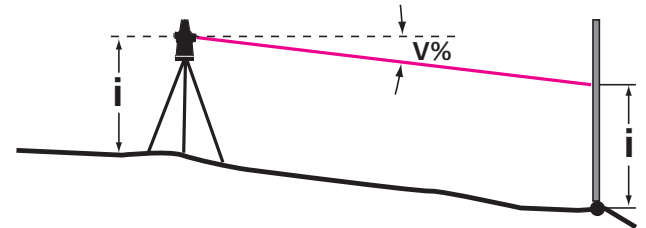
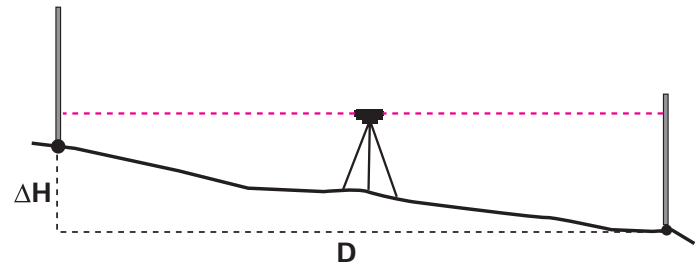

Measuring right-angles

The most accurate way to set out a right-angle is to use a theodolite or a total station. Position the instrument on the point along the survey line from which the right-angle is to be set out, target the end point of the survey line, set the horizontal circle to zero (see user manual) and turn the total station until the horizontal circle reading is 100 gon (90°).

For setting out a right-angle where the accuracy requirements are less demanding, e.g. for small buildings or when determining longitudinal and transverse profiles, the horizontal circle of a level can be used. Set up the level over the appropriate point of the survey line with the help of a plumb bob suspended from the central

fixing screw of the tripod. Then turn the horizontal circle by hand to zero in the direction of the survey line or of the longitudinal profile. Finally, turn the level until the index of the circle is set to 100 gon (90°).

An optical square is the best solution for the orthogonal surveying of a point on a survey line or vice versa, and for the setting out at right-angles of a point in the near distance. The beam of light from the object point is turned through 90° by a pentagonal prism so that it reaches the observer. The optical square consists of two superimposed pentagonal prisms with their fields of view facing right and left respectively. Between the two prisms is an unrestricted view of the object point. You as the

observer can position yourself in the survey line (defined by two vertically-positioned alignment rods) in that you move perpendicularly to the line until you see the images of the two rods exactly superimposed. Then you move yourself along the survey line until the object point and the two images of the alignment rods all coincide.

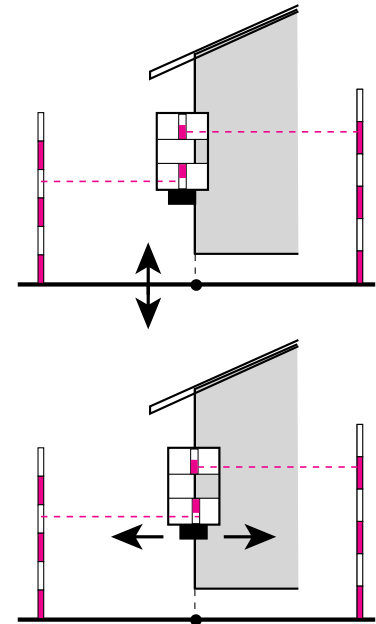

Calculating areas

1. Set up the total station in the terrain so that it is within view of the entire area to be surveyed. It is not necessary to position the horizontal circle.
2. Determine the boundary points of the area sequentially in the clockwise direction. You must always measure a distance.
3. Afterwards, the area is calculated automatically at the touch of a button and is displayed.

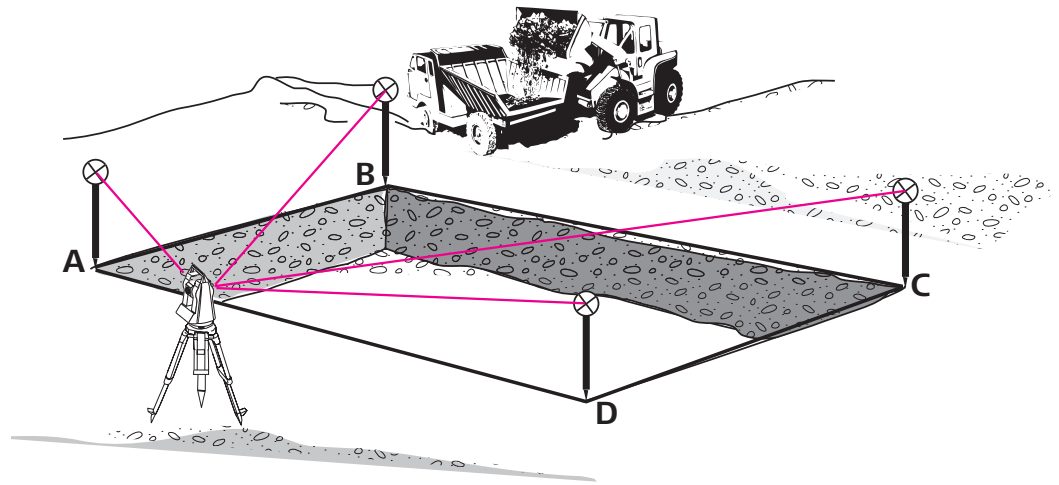

Staking out

1. Set up the instrument at a known point and position the horizontal circle (refer to the section "Setting the station" in the user manual).
2. Enter manually the coordinates of the point to be staked out. The program automatically calculates direction and distance (the two parameters needed for staking out).
3. Turn the total station until the horizontal circle reads zero.
4. Position the reflector at this point (point P').
5. Measure the distance; the difference in the distance ΔD to the point P will be displayed automatically.

Alternatively, the coordinates of the points to be staked out can be transferred beforehand, back in the office, from the computer to the total station. Under these circumstances, in order to stake out, only the point number then needs to be entered.

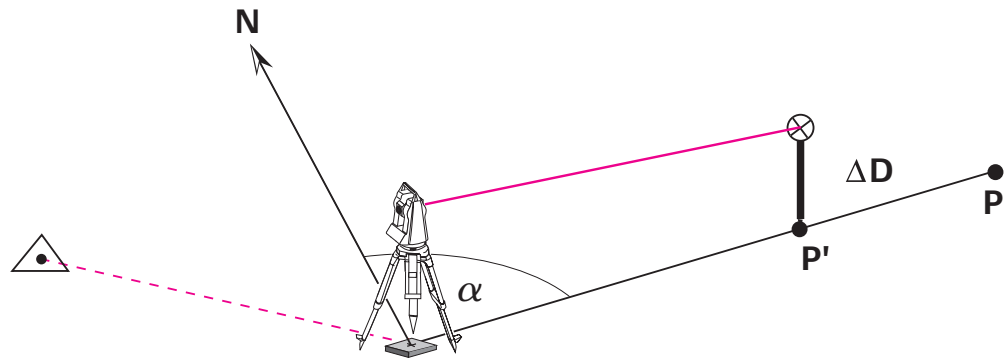

Remote heights

1. Set up a reflector vertically beneath that point the height of which is to be determined. The total station itself can be situated anywhere.
2. Measure the distance to the reflector.
3. Target the high point.
4. The height difference H between the ground point and the high point is now calculated at the touch of a button and is displayed.

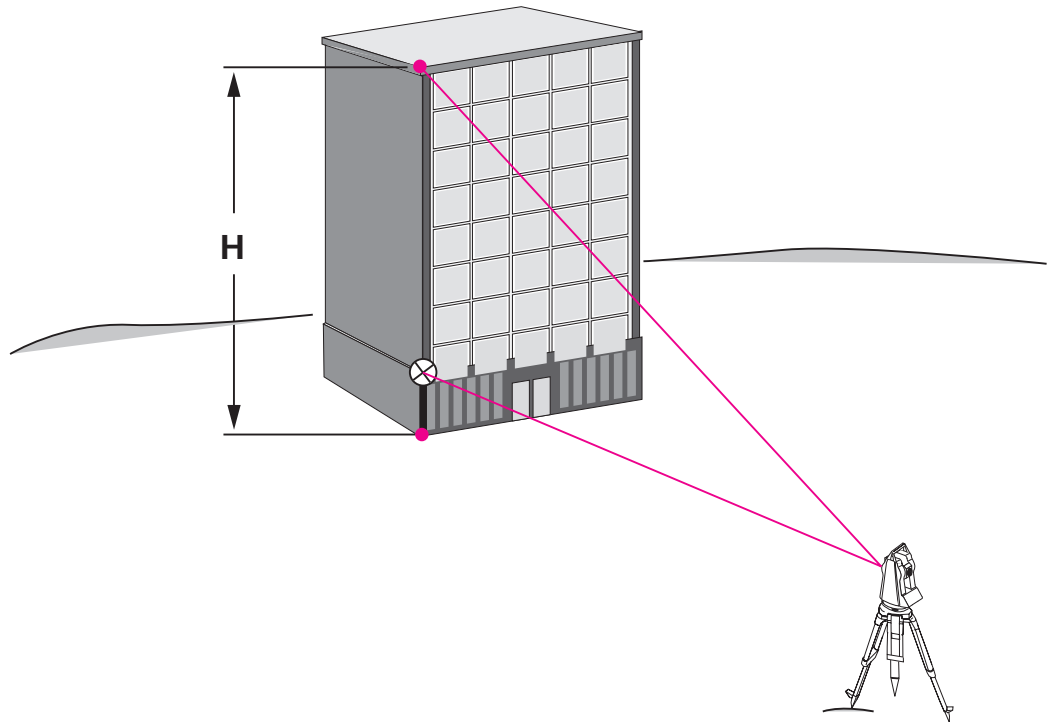

Tie distances

The program determines the distance and height difference between two points.

1. Set up the total station at any location.
2. Measure the distance to each of the two points A and B.
3. The distance D and the height difference H are displayed at the touch of a button.

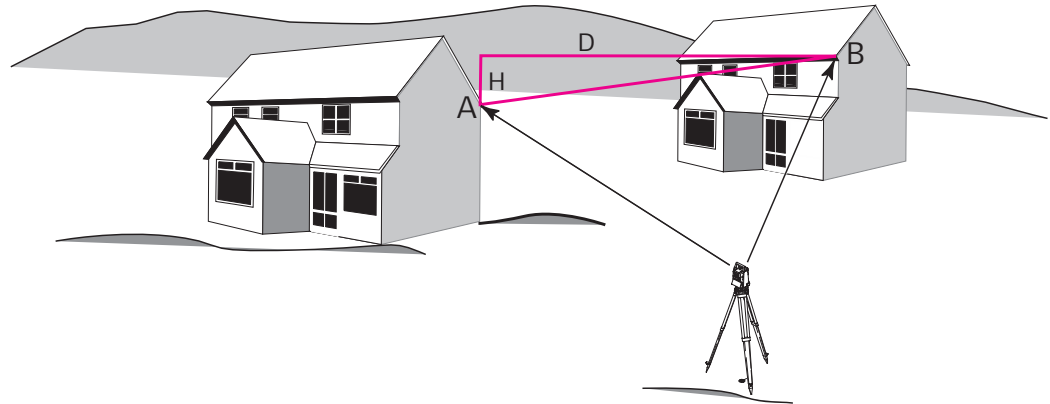

Free-station surveys

This program calculates the position and height of the instrument station, along with the orientation of the horizontal circle, from measurements to at least two points, the coordinates of which are known.

The coordinates of the tie points can be entered manually or they can be stored in the instrument beforehand.

Free stationing has the great advantage that, for large projects involving surveying or staking out, you can choose the most favourable station for the instrument. You are no longer forced to use a known point that is in an unsatisfactory location.

The options for measuring, and the measuring procedure, are described in detail in the user manuals.

Note:

When performing survey tasks that involve determining heights or staking them out, always remember to take the height of the instrument and that of the reflector into account.

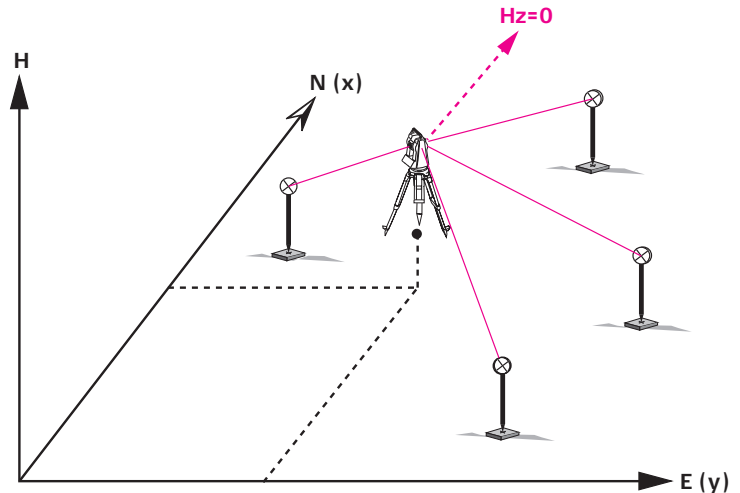

Surveying with GNSS (GPS & GLONASS)

GNSS surveys use the signals transmitted by satellites having trajectories such that any point on the Earth's surface can be determined around the clock and independently of weather conditions. The positioning accuracy depends on the type of GNSS receiver and on the observation and post-processing techniques used.

Compared with the use of a total station, GNSS surveying offers the advantage that the points to be measured do not have to be mutually visible. Today, provided that the sky is relatively unobstructed (by trees, buildings etc.) and therefore that adequate satellite signals can be received, GNSS equipment can be applied to many survey tasks that until recently

were carried out using electronic total stations.

The new GPS System 1200 from Leica Geosystems enables the most diverse range of survey tasks to be carried out with centimetre accuracy – on the tripod; on the plumbing pole; on ships, vehicles and construction plant; and using both static and kinematic applications.



GNSS Reference Stations

Also known as a Continuously Operating Reference Station (CORS), this is typically a multi-frequency GNSS receiver located at known coordinates, supplied with permanent power and connected to several communication devices.

A CORS normally logs GNSS data for use in post-processing tasks, or supplies real-time GNSS correction data to DGPS and/or RTK applications. In many cases, it performs both tasks satisfying the demands of many different applications including surveying, engineering, construction, geodetic control, GIS, monitoring, tectonic studies and hydro-graphy. With additional CORS, larger areas even countries can be covered with a CORS Network infrastructure.

CORS are controlled remotely by a specialised software program, such as Leica GPS Spider, which connects to the CORS via a range of telecommunication media; serial, radio or phone modem, even the Internet. Once configured, a CORS network with GPS1200 and GPS500 receivers will run continuously supplying the full range of GNSS data, DGPS, RTK and network RTK services to users in the network.

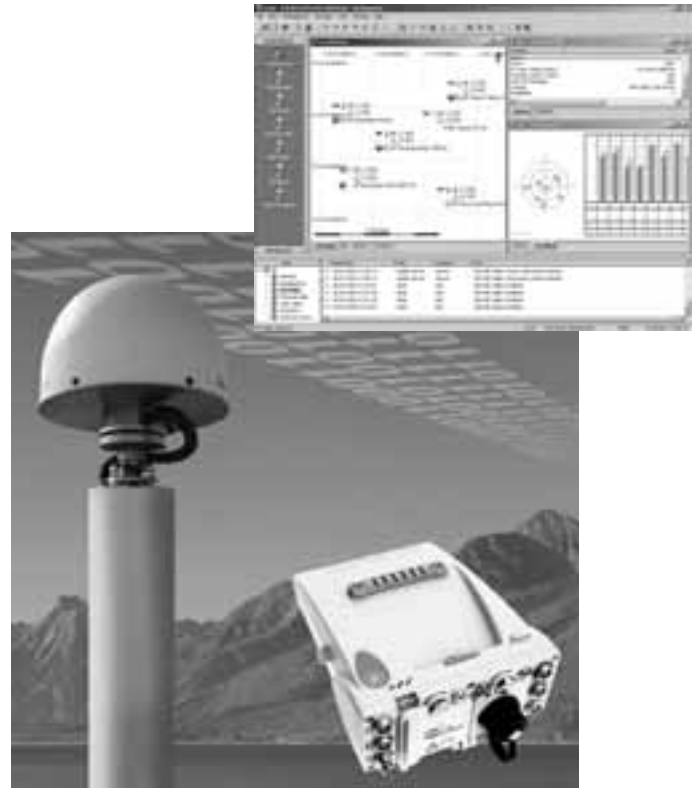

Illustrations, descriptions and technical data are not binding and may be changed.
Printed in Switzerland - Copyright Leica Geosystems AG, Heerbrugg, Switzerland, 2006.
722510en - I.07 - RVA

Leica Geosystems AG
Heerbrugg, Switzerland
www.leica-geosystems.com

- when it has to be **right**

Leica
Geosystems